



MAXX COLD X-series

Project Name:	
Location:	
Item:	Qty:
Model:	

MXH7.1F / MXH10.6F / MXH14.2F

FLAT GLASS DISPLAY FREEZER



MXH7.1F
7.1 Cu Ft



MXH10.6F
9.7 Cu Ft



MXH14.2F
11.8 Cu Ft

FEATURES

- Urethane insulated walls and doors
- External: White Painted panelling
- Internal: Aluminum panelling
- Recessed sliding door handles
- Utilizes environmentally friendly CFC-free R134A refrigerant
- Baskets included
- Exterior temperature display
- Front facing drainage for easier collection of water
- Locking Lids
- Casters: MXH7.1F and MXH10.6F Front Caster / Back Feet (1in)
MXH14.2F includes 4 casters (4in)
- Available in 115V/60Hz/1, 230/50Hz/1

MXH7.1F / MXH10.6F / MXH14.2F

MODEL	TEMP	VOLTAGE/HZ	AMPS	CORD LENGTH	COMPRESSOR	NEMA PLUG	INSULATION
MXH7.1F	0° - 10°F -17.7° - -23°C	115V/60Hz/1 230/50Hz/1	1.5	3 m	~1/10 HP	5-15 P	70 mm
MXH10.6F	0° - 10°F -17.7° - -23°C	115V/60Hz/1 230/50Hz/1	2	3 m	~1/10 HP	5-15 P	70 mm
MXH14.2F	0° - 10°F -17.7° - -23°C	115V/60Hz/1 230/50Hz/1	3	3 m	~1/5 HP	5-15 P	70 mm



Specifications subject to change without notice.

Approvals: ETL, CETL, ETL Sanitation approved



MAXX COLD X-series

MXH7.1F: 845035010552 | MXH10.6F: 845035010569 | MXH14.2F: 845035010576

MXH7.1F / MXH10.6F / MXH14.2F

FLAT GLASS DISPLAY FREEZER

DIMENSIONS

FRONT VIEW:

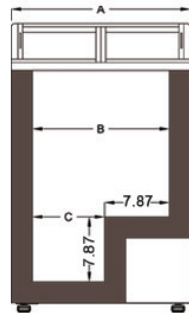

MXH7.1F

A 37.52 inch

B 32.28 inch

C 24.41 inch

SIDE VIEW:

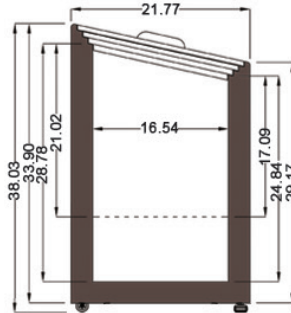

FRONT VIEW:

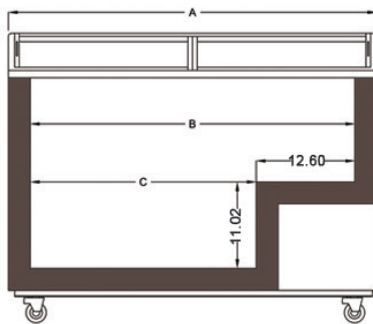

MXH10.6F MXH14.2F

A 47.05 inch 54.92 inch

B 41.30 inch 49.17 inch

C 28.70 inch 36.57 inch

SIDE VIEW:

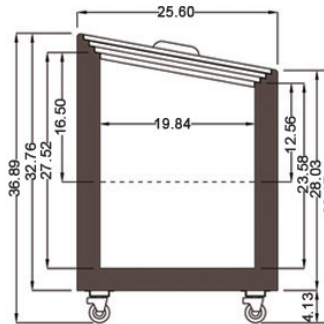

MODEL	DIMENSIONS (W"xD"x"H")	SHIPPING DIM (W"xD"x"H")	CAPACITY	UNIT WEIGHT	SHIP WEIGHT
MXH7.1F	37.52 x 21.77 x 38.03 953 x 553 x 918mm	40.9 x 25.2 x 38.4 1039 x 640 x 975mm	7.1 Cu Ft 201 L	105.8 lb 48 kg	110 lb 50 kg
MXH10.6F	47.05 x 25.60 x 36.89 1195 x 654 x 931mm	50.4 x 29.5 x 38.6 1280 x 749 x 980mm	9.7 Cu Ft 275 L	132.2 lb 60 kg	154 lb 70 kg
MXH14.2F	54.92 x 25.60 x 36.89 1395 x 654 x 931mm	58.3 x 29.5 x 38.6 1481 x 749 x 980mm	11.8 Cu Ft 334 L	147.7 lb 67 kg	174.2 lb 79 kg

MAXX COLD

3355 Enterprise Avenue - Fort Lauderdale - FL 33331 - Tel: 954.202.7419

www.TheLegacyCompanies.com