



BACK BAR COOLERS

SOLID DOOR &/or GLASS DOOR

MODELS: MXBB60_MXBB70_MXBB90_MXBB60G_MXBB70G_MXBB90G

INSTALLATION, MAINTENANCE & OPERATING MANUAL

Thank you for choosing our equipment for your operational requirements. **Follow these instructions carefully. If properly used and maintained, you can expect to enjoy years of reliable, efficient and top quality use.**

Note: Product line is subject to ongoing, continuous upgrades and improvements. The specifications defining each model are subject to change without notice.

Keep this manual for training and as a reference guide when service or maintenance is required.

Keep a copy of your Bill of Sale.

This will establish your appliance's warranty period and the date this coverage started.

SERIAL NUMBER INFORMATION

The serial number is located inside the unit on the left hand side, near the top, on the wall. Always have the serial number available when calling for parts or service.

**For AUTHORIZED PARTS or TECHNICAL SERVICE, please contact:
1-877-368-2797 or Service@MaxxHelp.com**

Distributed by Maximum Food Service • 3355 Enterprise Avenue, Suite 160, Weston, FL 33331 USA
Phone: (954) 202-7419 • Website: MaximumFoodService.com

TABLE OF CONTENTS

TECHNICAL SERVICE CONTACT INFORMATION	COVER
SAFETY PRECAUTIONS	3
PROPER DISPOSAL of your old REFRIGERATOR	
REPLACEMENT PARTS	4
HOW TO CONNECT ELECTRICITY	
UNPACKING	4 - 6
TRANSPORTATION and INSTALLATION	
OPERATION	7 - 8
CONTROL PANEL DISPLAY / COMMANDS	
Key Functions	
Key Combinations	
Function of LEDs	
MAIN FUNCTIONS	
How to See the Set Point	
How to Change the Set Point	
How to Start a Manual Defrost	
How to Lock the Keyboard	
How to Unlock the Keyboard	
ALARM SIGNALS	9
MAINTENANCE	9 - 11
Stainless Steel Care and Cleaning	
Gasket Maintenance	
Cleaning the Condenser	
Swing Door Replacement and Adjustment	
Sliding Door Replacement and Adjustment	
TROUBLESHOOTING	12
TECHNICAL SPECIFICATIONS	12
WIRING DIAGRAMS	13-15
WARRANTY INFORMATION	16

SAFETY PRECAUTIONS

When using electrical appliances, basic safety precautions should be followed, including the following:

- Equipment must be properly installed and located in accordance with the Installation Instructions.
- Do not allow children to climb, stand, crawl inside or hang on to the equipment.
- Do not touch the cold surfaces in the refrigerator compartment when hands are damp or wet. Skin may stick to these extremely cold surfaces.
- Do not store or use gasoline or other flammable vapors and liquids in the vicinity of this or any other appliance. Do not store explosive substances such as aerosol cans with a flammable propellant in this appliance.
- Keep fingers out of the “pinch point” areas; clearances between the doors and between the doors and cabinet are necessarily small; be careful closing doors when children are in the area.
- Unplug the equipment before cleaning and making repairs.
- The insulation including any electrical, plumbing and mechanical details must comply with all applicable local codes and ordinances.

NOTE: We strongly recommend that any servicing be performed by a qualified technician.



WARNING

- The manufacturer has a policy of continuous improvement on our products and reserve the right to change materials and specifications without notice. To confirm the specific parameters, please refer to the name plate ratings.
- The refrigerator requires periodic maintenance and cleaning. Failure to provide this care voids the appliances warranty.
- Unplug the refrigerator before cleaning and making repairs.
- Setting temperature controls to the ZERO (0) position does not remove power to the light circuit, perimeter heaters, or evaporator fans.

LOSS OR SPOILAGE OF PRODUCTS IN YOUR APPLIANCE IS NOT COVERED BY WARRANTY.

IN ADDITION TO FOLLOWING RECOMMENDED INSTALLATION PROCEDURES. PLEASE RUN THE APPLIANCE 24 HOURS PRIOR TO USAGE. DO NOT LOAD THE UNIT WITH PRODUCT AT START-UP OR AFTER A PROLONGED SHUTDOWN UNTIL THE UNIT IS AT THE PROPER INTERNAL HOLDING TEMPERATURE. (COOLDOWN PERIOD CAN BE AS LONG AS 10 HOURS).

PROPER DISPOSAL OF YOUR OLD REFRIGERATOR

If you are getting rid of your old appliance, please follow these instructions, at minimum:
BEFORE YOU THROW AWAY YOUR OLD APPLIANCE:

- Take off the doors.
- Leave the shelves in place so that children may not easily climb inside.

APPLIANCE DISPOSAL

When recycling appliance please make sure that the refrigerants are handled according to local and national codes, requirements and regulations.

REFRIGERANT DISPOSAL

Make sure the refrigerant is removed for proper disposal by a qualified service technician. If you intentionally release

any refrigerants you can be subject to fines and imprisonment under provisions of the environmental regulations.

REPLACEMENT PARTS

- Component parts shall be replaced with like components. Always use the manufacturer authorized / provided parts for the best results.
- Servicing shall be done by authorized service personnel, to minimize the risk of further damage due to incorrect parts or improper service.
- If the supply cord is damaged, it must be replaced by a special cord or assembly available from the manufacturer or its approved / authorized service agent.



WARNING

HOW TO CONNECT ELECTRICITY

DO NOT, UNDER ANY CIRCUMSTANCES, CUT OR REMOVE THE GROUND PRONG FROM THE POWER CORD. FOR PERSONAL SAFETY, THIS APPLIANCE MUST BE PROPERLY GROUNDED.

- The power cord from this appliance is equipped with a grounding plug which minimizes the possibility of electric shock hazard.
- Have the wall outlet and circuit checked by a qualified electrician to make sure the outlet is properly grounded.
- It is your personal responsibility and obligation to have your outlet replaced with the properly grounded wall outlet.
- The refrigerator should always be plugged into its own individual dedicated electrical circuit, which has a voltage rating that matches the rating plate. This provides the best performance and also prevents overloading building wiring circuits which could cause a fire hazard from overheated wires or tripping a circuit breaker / blowing a protective fuse.
- Never unplug the equipment by pulling on the power cord. Always grip plug firmly and pull straight out from the outlet.
- Repair or replace immediately all power cords that have become frayed or otherwise damaged.
- Do not use a cord that shows cracks or abrasion damage along its length or at either end.
- When removing the equipment away from the wall, be careful not to roll over or damage the power cord. If power cord is damaged it should be replaced with original equipment manufacturer parts. To avoid hazard this should be done by a qualified service technician.
- Do not plug the power cord into an extension cord or an adaptor. This can create a fire hazard or short circuit.



WARNING

Compressor warranties are void if compressor burns out due to low voltage.

Power supply cord ground should not be removed!

Do not use electrical appliances inside the compartments of this equipment.

UNPACKING

This unit was carefully inspected before leaving the factory. Upon acceptance of the shipment, the transportation company assumes full responsibility for its safe delivery.

- Immediately after unpacking, check for possible shipping damage or concealed damage.
- If the unit is damaged, save the packaging material and contact the carrier within 2 days of delivery. Request an inspection by the shipping company of the damaged equipment.
- In the event that the exterior is not damaged, yet upon opening, there is concealed damage to the equipment, notify the carrier. Do this verbally and in writing.
- Be certain to check the compressor compartment housing and visually inspect the appliance's package. Be sure lines are secure and base is still intact.
- Freight carriers can supply the necessary damage forms upon request.
- Retain all crating material until an inspection has been made or waived.

TRANSPORTION and INSTALLATION



WARNING

Standard warranties will be void due to improper installation procedures.

1. When you transport the refrigerator, the angle between the compartment body and the ground should be no more than 45°, and you should never place the refrigerator up-side down.
2. Do not use any of the external part as loading points, for example, the condenser on the back, the door or the hinge.
3. When the refrigerator is installed or used, all the package (including board and foam plastic) should be properly disposed of. Please recycle, when possible.
4. Install the refrigerator in a dry place to prevent the compartment body from rusting, which may (1) affect the electric insulation (2) create a food safety contamination risk and (3) reduce the appliance's expected useful life.

Location:

Units represented in this manual are intended for indoor use only. It should be placed far from any heat source and not under direct sunshine to avoid less efficient performance due to the high ambient temperature. Be sure the location chosen has a floor strong enough to support the total weight of the cabinet and contents. A fully loaded unit can weigh as much as 1500 pounds. Reinforce the floor as necessary to provide for maximum loading. For the most efficient refrigeration, be sure to provide good air circulation inside and out. Keep the refrigerator stable and level to avoid vibration and noise.

Inside cabinet:

Do not pack refrigerator so full that air cannot circulate. The refrigerated air is discharged at the top rear of the unit. It is important to allow for proper air flow from the top rear to the bottom of the unit. Obstructions to this air flow can cause evaporator coil freeze ups and loss of temperature or overflow of water from the evaporator drain pan. The shelves have a rear turn up on them to prevent this. However, bags and other items can still be located to the far rear of the cabinet. Air is brought into the evaporator coil with fans mounted to the front of the coil. Prevent obstruction of the cooling air by locating large boxes, solid and/or tall stacks of product at the bottom of the cabinet.

Outside cabinet:

Be sure that the unit has access to ample air. Avoid hot corners and locations near stoves and ovens. It is recommended that the unit be installed no closer than 2" from any wall with at least 12" of clear space above the unit. Should it become necessary to lay the unit on its side or back for any reason, allow at least 24 hours before start-up so as to allow compressor oil to flow back to the sump. Failure to meet this requirement can cause compressor failure and unit damage.

Leveling

A level cabinet looks better and will perform better because the doors will line up with the frames properly, the cabinet will not be subject to undue strain and the contents of the cabinet will not move around on the shelves. Use a level to make sure the unit is level from front to back and side to side. Units supplied with legs will have adjustable bullet feet to make the necessary adjustments. If the unit is supplied with casters, no adjustments are available. Ensure the floor where the unit is to be located is level. If the floor is not level where the unit is to be located, shims or chocks may be need to enable the unit to be level.

Stabilizing

Models are supplied on casters for your convenience, ease of cleaning underneath and for mobility. It is very important, however, that the cabinet be installed in a stable condition with the front wheels locked while in use.

**The factory warranty does not cover food product loss.**

The ON/OFF switch must be turned to OFF and the unit disconnected from the power source whenever performing service, maintenance functions or cleaning the refrigerated area.

CAUTIONS:

1. The refrigerator must be properly grounded to avoid a shock hazard.
2. In case of any damage to the electric wires and/or plug, please contact an authorized electrician to repair the connection.
3. If the voltage is unstable, please provide a suitable automatic voltage regulator and/or surge protection.
4. Allow the refrigerator to reach its operating temperature before it is loaded with product.
5. You should adjust the temperature control according to the required temperature and quantity/tiers of the stored food and the environmental temperature/required conditions for the stored product to maintain its quality.
6. Unplug the appliance by pulling the cord cap (plug) NOT the electrical cord.
7. Do not overfill the unit. There should be reasonable space between the food items for better temperature regulation.
8. If a power outage occurs, you should wait at least 5 minutes before the refrigerator is turned on again to avoid damage to the compressor.
9. Never store any flammable, explosive and corrosive liquid or gas in the refrigerator. Keep it away from this appliance.

NOTE! Before loading product we recommend you run the unit empty for at least 24 hours. This allows you to be sure electrical wiring and installation are correct and no shipping damage has occurred.

OPERATION

On/Off Switch:

An on/off switch is located on the front of the bottom shroud. When the unit is on, the switch will glow green.

Light Switch:

An light switch is located next to on/off switch on the front of the shroud.



WARNING

Do not throw items into the storage area.

Failure to heed this recommendation could result in damage to the interior of the cabinet.

CONTROL PANEL DISPLAY / COMMANDS

KEY FUNCTION

SET: To display target set point; in programming mode it selects a parameter or confirm an operation.



To start a manual defrost.

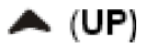

(UP)

To see when the last temperature alarm happened; in programming mode it browses the parameter codes or increases the display value



(DOWN)

To see when the last temperature alarm happened; in programming mode it browses the parameter codes or decreases the display value

KEY COMBINATION



To lock & unlock the keyboard











To enter in programming mode



To return to the room temperature display

FUNCTION of LEDs

LED	MODE	FUNCTION
	ON	Compressor enabled
	Flashing	<ul style="list-style-type: none">• Programming Phase - flashing with • Anti-short cycle delay enabled
	ON	Defrost enabled
	Flashing	<ul style="list-style-type: none">• Programming Phase - flashing with • Drip time in progress
	ON	Fans enabled
	Flashing	Fans delayed after defrost in progress
	ON	Temperature alarm has occurred

MAIN FUNCTIONS

HOW TO SEE THE SET POINT

1. Push and immediately release the SET key: the display will show the set point value.
2. Push and immediately release the SET key or wait for 5 seconds to display the sensor value again.

HOW TO CHANGE THE SET POINT

1. Push the SET key for more than 2 seconds to change the set point value.
2. The value of the set point will be displayed and the  LED starts blinking.
3. To change the set value push the UP or DOWN key within 10 seconds.
4. To memory the new set point value and push the SET key again or wait 10 seconds.

HOW TO START A MANUAL DEFROST

Push the  key for more than 2 seconds and a manual defrost will start

HOW TO LOCK THE KEYBOARD

1. Keep pressed the UP and DOWN keys for more than 3 seconds.
2. The “POF” message will be displayed and the keyboard will be locked. At this point, it will be possible only to see the set point or the MAX or Min temperature stored
3. If a key is pressed more than 3s the ”POF” message will be displayed.

HOW TO UNLOCK THE KEYBOARD

Keep pressed the UP and DOWN keys together for more than 3 seconds, till the “Pon” message displays. Then press the UP and DOWN keys to select the item to check or the program.

ALARM SIGNALS

HOW TO SEE THE ALARM AND RESET THE RECORDED ALARM

1. Push the UP or DOWN key. The alarm signals will display
2. When the signal is displayed, hold the SET key until the "rst" message is displayed, and push the SET key again, the "rst" message start blinking and the normal temperature will be displayed again.
- 3.

MESSAGE	CAUSE	OUTPUTS
P1	Room Probe Failure	Compressor output according to par. "Con" or "COF"
P2	Evaporator Probe Failure	Defrost end is timed
P3	Condenser Probe Failure	Output unchanged
HA	Maximum Temperature Alarm	Output unchanged
LA	Minimum Temperature Alarm	Output unchanged
dA	Door Open	Compressor and fans restart
EA	External Alarm	Output unchanged
CA	Serious External Alarm (i1F = bAL)	All outputs OFF
cSd	Condenser Alarm	All outputs OFF

MAINTENANCE



The power switch must be turned to OFF and the unit disconnected from the power source whenever performing service, maintenance functions or cleaning the refrigerated area.

Do not use an abrasive cleaner. It will scratch the stainless steel and plastic and can damage the breaker strips and gaskets. Never use an acid based cleaning solution! Many food products have an acidic content which can deteriorate the finish. Be sure to clean the stainless steel surfaces of ALL food products.

The interior and exterior can be cleaned using soap and warm water.

If this isn't sufficient, try ammonia and water or a nonabrasive liquid cleaner.

When cleaning the exterior, always rub with the "grain" of the stainless steel to avoid marring the finish.

STAINLESS STEEL CARE and CLEANING

To prevent discoloration of rust on stainless steel several important steps need to be taken. Proper cleaning of stainless steel requires soft cloths or plastic scouring pads.

Cleaning solutions need to be alkaline based or non-chloride cleaners. Any cleaner containing chlorides will damage the protective film of the stainless steel. Chlorides are also commonly found in hard water, salts, and household and industrial cleaners. If cleaners containing chlorides are used be sure to rinse repeatedly and dry thoroughly upon completion.

Routine cleaning of stainless steel can be done with soap and water. Extreme stains or grease should be cleaned with a non-abrasive cleaner and plastic scrub pad. It is always good to rub with the grain of the steel. There are also stainless steel cleaners available which can restore and preserve the finish of the steels protective layer.

Early signs of stainless steel breakdown can consist of small pits and cracks. If this has begun, clean thoroughly and start to apply stainless steel cleaners in attempt to restore the passivity of the steel.

GASKET MAINTENANCE

Gaskets require regular cleaning to prevent mold and mildew build up and also to keep the elasticity of the gasket. Gasket cleaning can be done with the use of warm soapy water. Avoid full strength cleaning products on gaskets as this can cause them to become brittle and prevent proper seals. Also, never use sharp tools or knives to scrape or clean the gasket which could possibly tear the gasket and rip the bellows. Gaskets can easily be replaced and don't require the use of tools or authorized service persons. The gaskets are "Dart" style and can be pulled out of the grove in the door and new gaskets can be "pressed" back into place.

DOORS / HINGES

Over time and with heavy use doors the hinges may become loose. If it is noticed that the door is beginning to sag, it may become necessary to tighten the screws that mount the hinge brackets to the frame of the unit. If the doors are loose or sagging this can cause the hinge to pull out of the frame which may damage both the doors and the door hinges. In some cases this can require qualified service agents or maintenance personnel to accomplish a fix that results in a properly hung, secure door that latches or closes properly and opens easily.

DRAIN MAINTENANCE

Each unit has a drain located inside the unit which removes the condensation from the evaporator coil and evaporates it at an external condensate evaporator pan (or it may deposit the condensation into a floor drain). Each drain can become loose or disconnected from moving or bumping the drain. If you notice excessive water accumulation on the inside of the unit, be sure the drain tube is connected from the evaporator housing to the condensate evaporator drain pan. If water is collected underneath the unit you may want to check the condensate evaporator drain tube to be sure it is still located inside the drain pan. The leveling of the unit is important as the units are designed to drain properly when on a level surface, if your floor is not level this can also cause drain problems. Be sure all drain lines are free of obstructions typically food product is found blocking drain lines causing water to back up and overflow the drain pans.

CLEANING THE CONDENSOR (Related Warranty Information)

- Condensers will accumulate dirt and require cleaning every 30 days.
- Dirty condensers result in compressor failure, product loss, and lost sales, which are not covered by warranty.
- If you keep the Condenser clean you will minimize your service expense and lower your electrical costs.
- The Condenser requires scheduled cleaning every thirty days or as needed.
- Air is pulled through the Condenser continuously, along with dust, lint, grease, etc.
- A dirty Condenser can result in voiding the unit's warranty coverage, as well as, compressor failure, product loss and loss of product sales.
- Proper cleaning involves removing dust from the Condenser. By using a soft brush, or vacuuming the Condenser with a shop vac, or using CO₂, nitrogen, or pressurized air.
- If you cannot remove the dirt adequately, please call our technical service number and we will refer you to local companies.
- On most of the units the condenser is accessible in the rear of the unit. You may need to remove the cabinet grill to expose the refrigeration system and piping network.
- The Condenser looks like a group of vertical fins. You need to be able to see through the condenser for the unit to function at maximum capacity. Do not place filter material in front of condensing coil. This material blocks air-flow to the coil similar to having a dirty coil.

THE CLEANING OF THE CONDENSER IS NOT COVERED BY THE WARRANTY!

HOW TO CLEAN THE CONDENSER:

1. Disconnect the electrical power to the unit.
2. Remove the louvered grill.
3. Vacuum or brush the dirt, lint, or debris from the finned condenser coil.
4. If you have a significant dirt build up you can blow out the condenser with compressed air.

NOTE: TO AVOID EYE INJURY, EYE PROTECTION IS RECOMMENDED.

5. When finished be sure to replace the louvered grill. The grill protects the condenser.
6. Reconnect the electrical power to the unit.

If you have any questions, please call our Technical Service Department, 1-877-368-2797.

SWING DOOR REPLACEMENT and ADJUSTMENT

1. Open the bottom shroud and hold the door, then loose bottom hinge's screws and take off the old door.
2. Prepare new door, insert top pin into top hinge, get one bottom hinge to hold the door by the bottom pin, then fasten bottom hinge securely to the door frame with three screws.
3. Allow the door to freely swing, make sure it swing close by itself with no restriction.
4. Plug the unit in and make sure the lock work well.
5. If not, adjust the door height by adding the plastic spacer/washer provided to the bottom hinge pin.

SLIDING DOOR REPLACEMENT and ADJUSTMENT

1. Remove the door counterweight hook from the top of the door.
2. Hold the door up until it's bottom edge over the channel a little, move the door out across the channel, lay the door down.
3. Prepare new door, hold the door insert into top channel until bottom edge over bottom channel, move bottom of door across the channel wall and lay it down to the channel.

TROUBLESHOOTING

ISSUE	REASON	SOLUTION
Compressor is Not Running	Fuse blown or circuit breaker tripped	Replace fuse or reset circuit breaker.
	Power cord unplugged	Plug in power cord.
	Thermostat is set too high	Set thermostat to lower temperature.
Cabinet Temperature is Too Warm	Thermostat is set too high	Set thermostat to lower temperature.
	Airflow is blocked	Re-arrange products to allow for proper air flow. Make sure there is at least 4 inches of clearance from the fan.
	Low refrigerant levels	Contact a service technician to check refrigerant levels.
	Door is slightly ajar	Make sure door is completely closed.
Interior Light is Not Working	Poor switch connection	Turn off light switch and turn it back on.
	Bulb is not connected	Make sure the bulb is correctly inserted in the socket.
	Bulb has burned out	Replace the bulb.
Condensation is Collecting on the Cabinet and/or Floor	Gasket is not sealing properly	Clean, repair, or replace the gasket as necessary.
	Floor drain is clogged or mispositioned	Check and fix the drain line flow to enter the floor drain.
	The condensation evaporator is full	Check the pan and check the heater. If the unit can't keep up, the room is too humid. Adjust the air conditioner setting or replace the heater with the higher wattage model.

NOTE: If the unit continues to have issues and you cannot solve the troubles according to the above-mentioned troubleshooting information or guidelines, please contact an authorized service agent. Do not handle it yourself unless you are a trained and licensed refrigeration technician.

TECHNICAL SPECIFICATIONS

For TECHNICAL SPECIFICATIONS, please visit our website at www.MaxximumFoodService.com.

**For AUTHORIZED PARTS or TECHNICAL SERVICE, please contact:
1-877-368-2797 or Service@MaxxHelp.com**

WIRING DIAGRAM:

60" and 70" Units

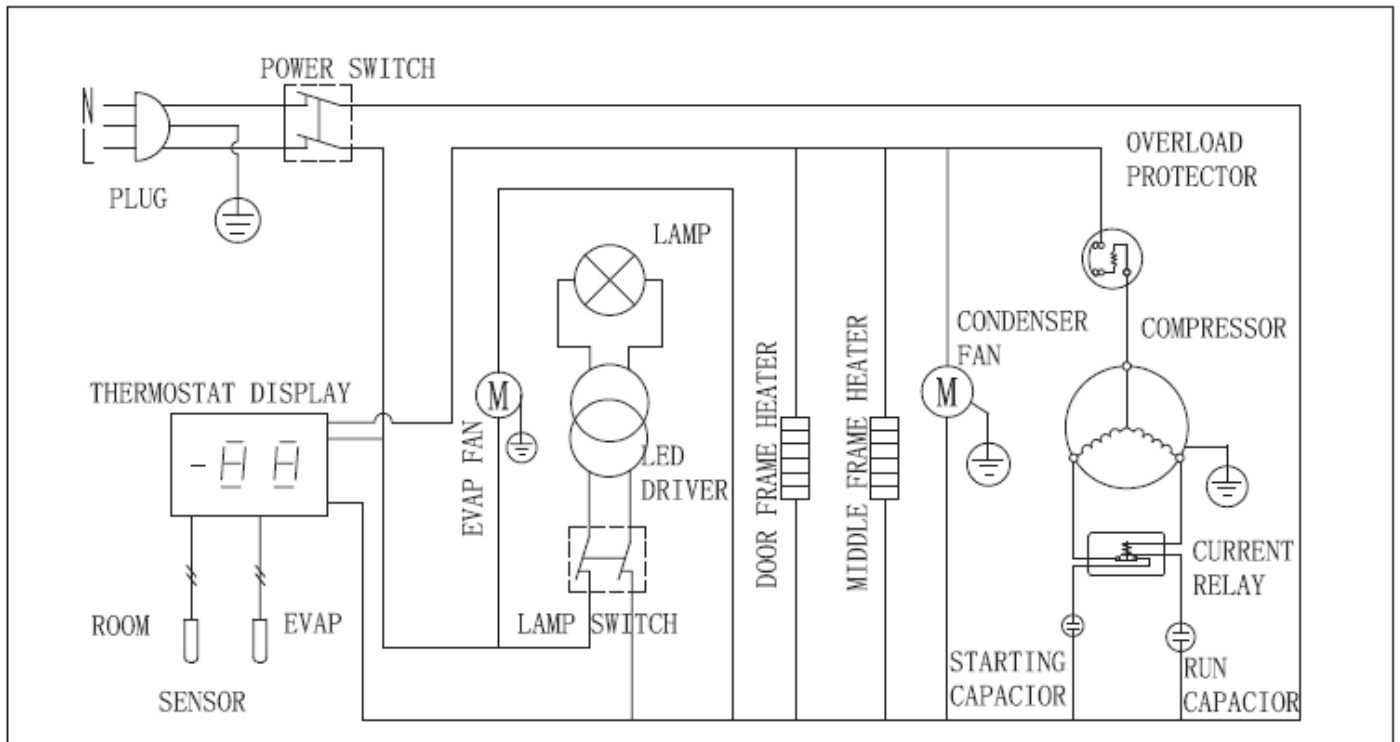

90" Units

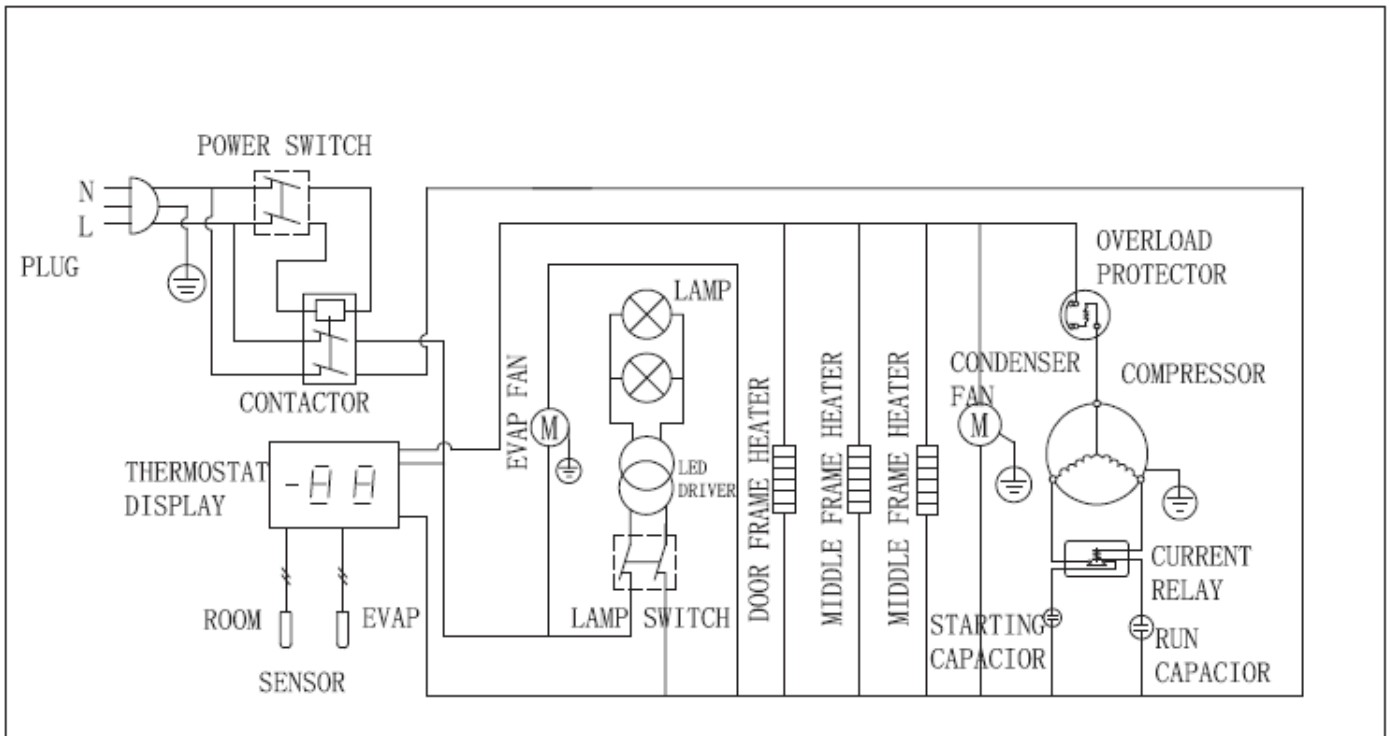

60" and 70" Units

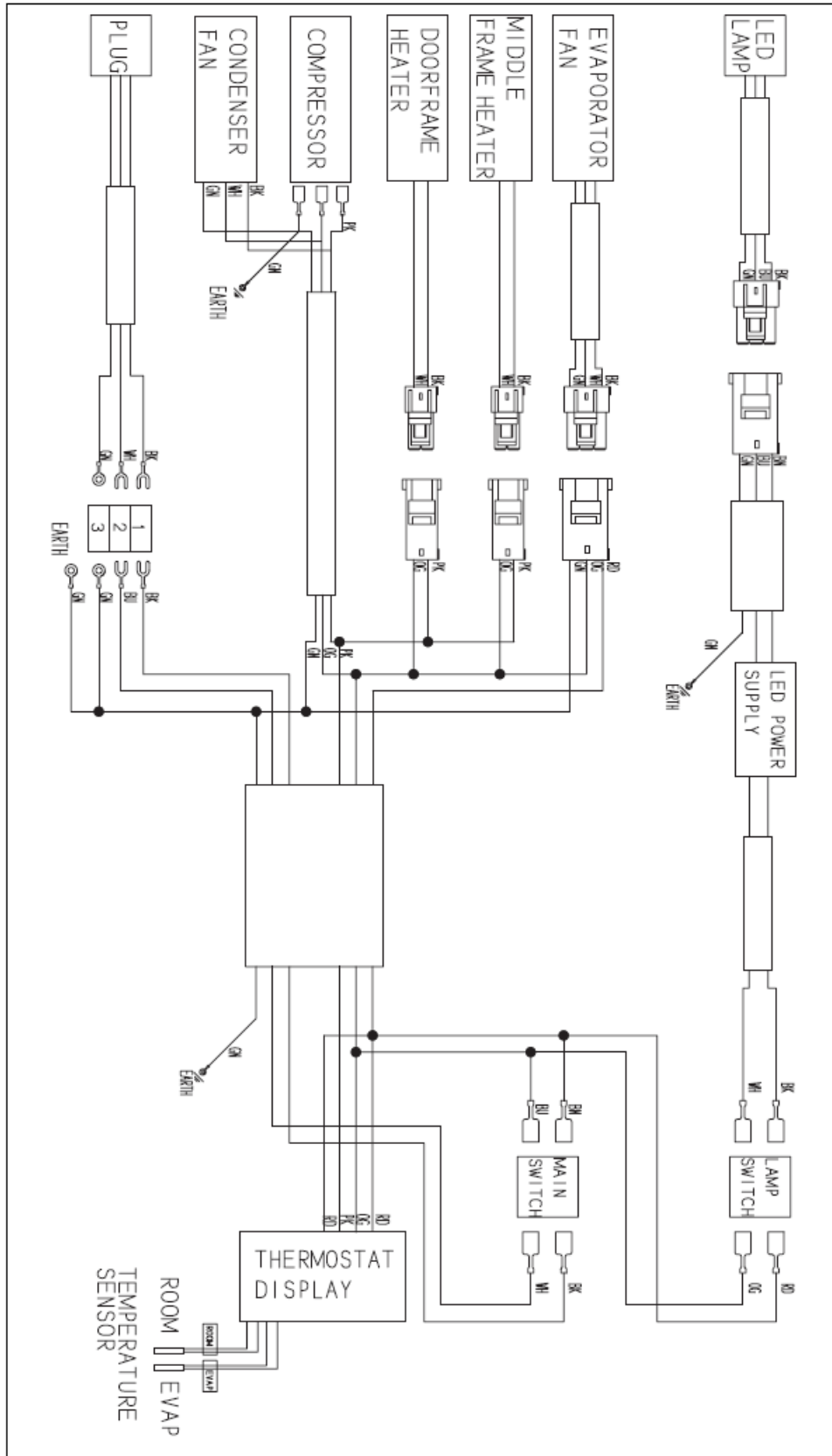

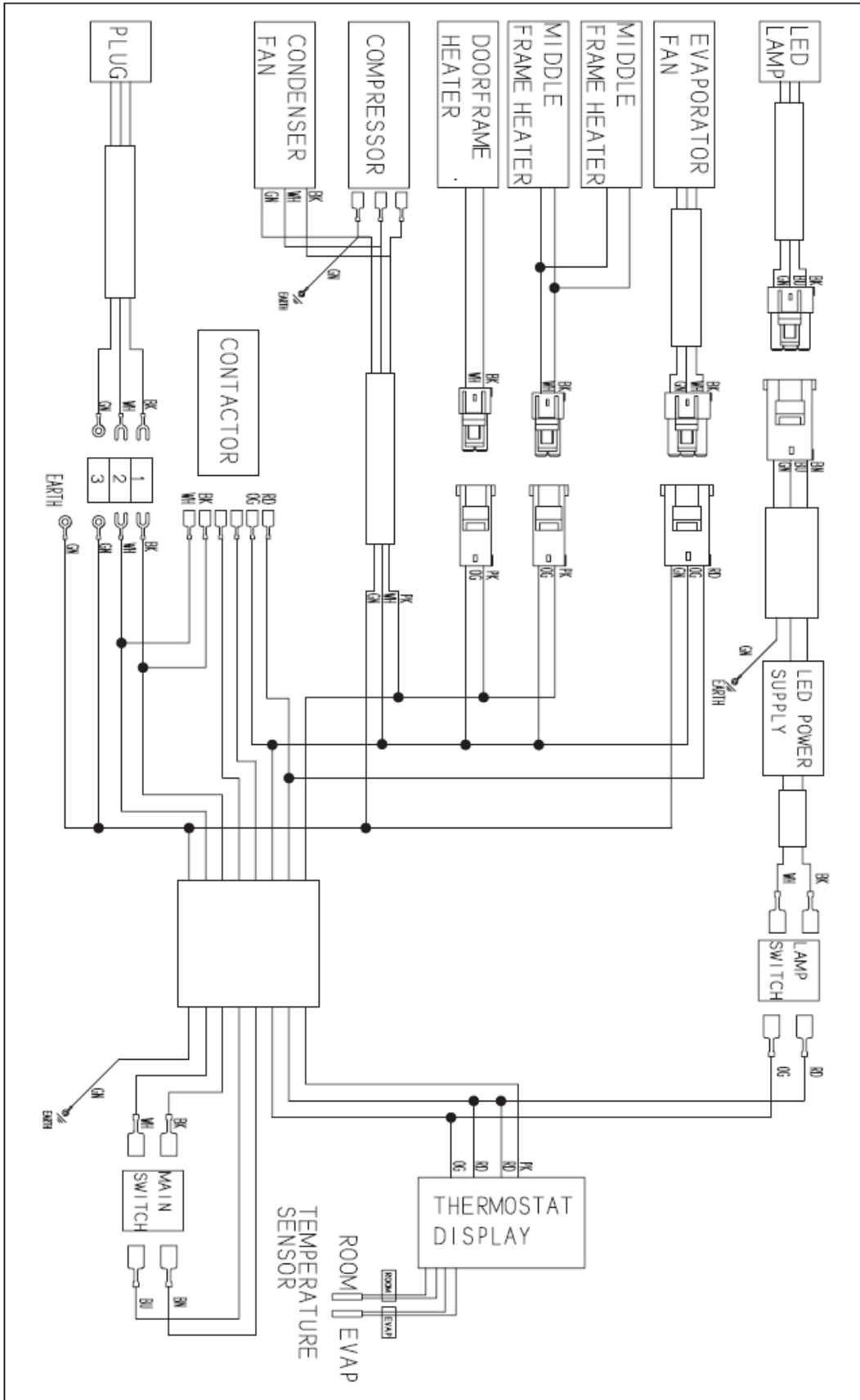

LIMITED WARRANTY

For Warranty details, please refer to:
www.MaxximumFoodService.com or 1-877-368-2797 or Service@MaxxHelp.com

A warranty card should have been included with your appliance.
However, if the warranty card is missing with your product, please send the following information to:

Warranty & Reference Data Sheet: (make a return copy standard post card size)

**Maxximum Food Service
WARRANTY CARD
C/O Technical Services
3355 Enterprise Avenue, Suite 160 Fort Lauderdale, FL 33331**

Brand & Model Number _____ Serial Number _____

Date of Installation _____ Name of Installer _____
or "Plug and Play" Hook-up

Clearance in front of, to the side, and behind the louvered cooling panels for utility compartment?

Temperature of the refrigerator compartment _____

Is there a rear open passageway for air flow? ____ yes ____ no

Is there an open air passageway along the floor of the unit for air flow? ____ yes ____ no

Is there sufficient space for air flow around each item in the cold air compartment? ____ yes ____ no

Are any shelves sagging? ____ yes ____ no

Is the internal lighting functioning properly? ____ yes ____ no

When the unit is turned on does the power light glow? ____ yes ____ no

Relative humidity of the neighboring environment? _____

_____ (PLEASE INITIAL) The installation Manual has been read and understood.

Date _____