

KOLD-DRAFT®

Project Name:

Location:

Item:

Qty:

Model:

KMXCB-72

CHEF BASES



KMXCB-72

FEATURES

KOLDRAFT Chef Bases is designed for the ultimate in value. Temperature is digitally controlled and easily viewed from the exterior of the cabinet. Stainless steel exterior construction ensures years of long life and maximum durability. KOLDRAFT Chef Bases provides unsurpassed quality at a value price.

- Urethane insulated walls and doors
- Recessed drawer handles
- 5" casters standard
- Utilizes environmentally friendly refrigerants using R134A
- Forced-air refrigeration
- Efficient cooling system
- Automatic defrost system
- Available in 220V/60Hz/1

Safety

Environmental/Sanitation



Specifications subject to change without notice.

Approvals: UL, UL Sanitation Approved

DIMENSIONS

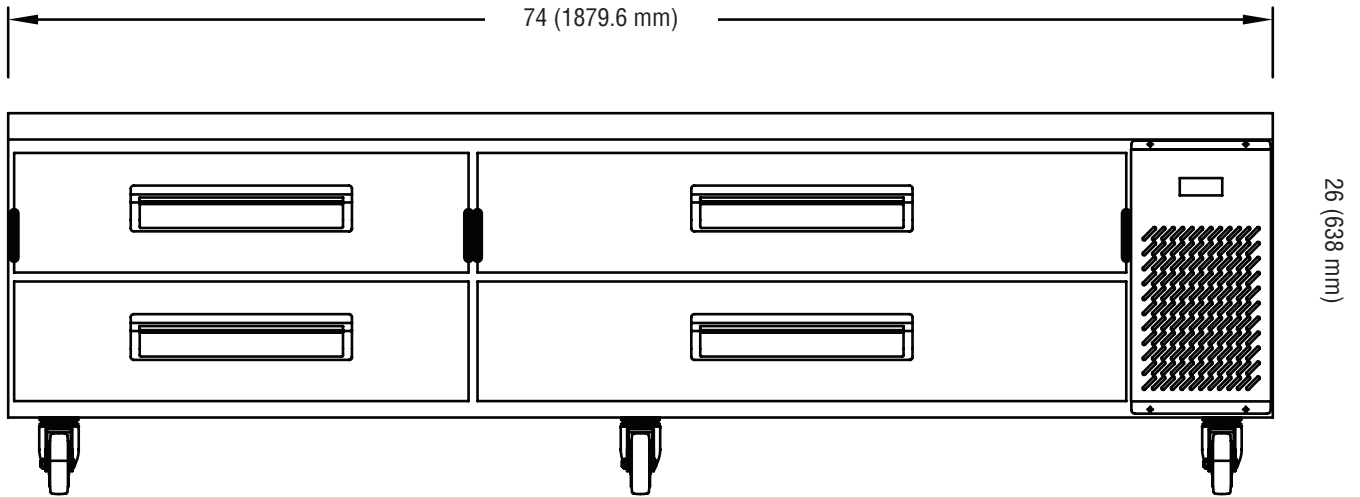

Model	Dim (W"xD"xH")	Capacity	Temp	Watts	Drawers	Weight
KMXCB-72	74 x 31.9 x 26 1879.6 x 775 x 638mm	11.1 Cu Ft 314 L	33° to 41°F .5° to 5°C	862	4	313 lb 142 kg