

KOLD-DRAFT®

Project Name:

Location:

Item:

Qty:

Model:

KMXCB-50

CHEF BASES



KMXCB-50

FEATURES

KOLDRAFT Chef Bases is designed for the ultimate in value. Temperature is digitally controlled and easily viewed from the exterior of the cabinet. Stainless steel exterior construction ensures years of long life and maximum durability. KOLDRAFT Chef Bases provides unsurpassed quality at a value price.

- Urethane insulated walls and doors
- Recessed drawer handles
- 5" casters standard
- Utilizes environmentally friendly refrigerants using R134A
- Forced-air refrigeration
- Efficient cooling system
- Automatic defrost system
- Available in 220V/60Hz/1

Safety

Environmental/Sanitation



Specifications subject to change without notice.

Approvals: UL, UL Sanitation Approved

KMXCB-50

072117

KOLDRAFT
1525 East Lake Road - Erie - PA 16511 - Tel: 800.840.9577
www.kold-draft.com

DIMENSIONS

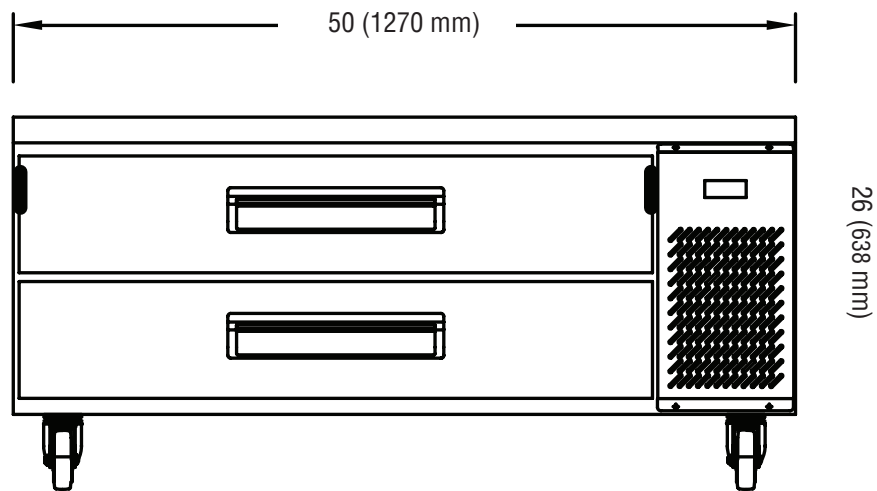

| Model | Dim (W"xD"xH") | Capacity | Temp | Watts | Drawers | Weight |
|----------|--------------------------------------|--------------------|---------------------------|-------|---------|------------------|
| KMXCB-50 | 50 x 31.9 x 26 1270 x 775 x 638mm | 6.5 Cu Ft 184 L | 33° to 41°F .5° to 5°C | 862 | 2 | 234 lb 106 kg |